

GS301 | YORKVILLE | Colombo Design

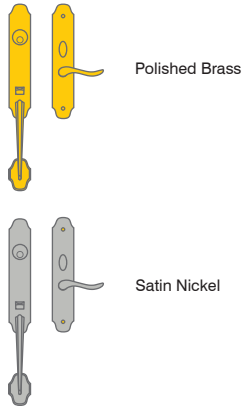

material: brass

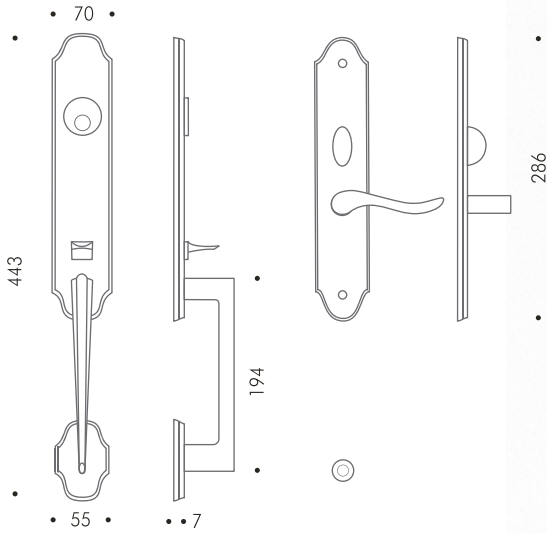

All front entry grip sets are made from the finest brass forgings, with only the very best finishing technology available. Each Set comes with a Grade 1, 3HR UL rated mortise case to provide an incredibly durable mechanism, to compliment each stylish model.

And combined with ANY Colombo door lever, each entry set can match the interior door trim, thus creating a uniform look throughout an entire home.

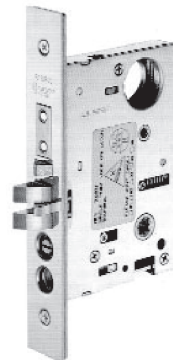

Installation and Door Preparations for Front Entry Gripset GS301

(Non-bored door condition)

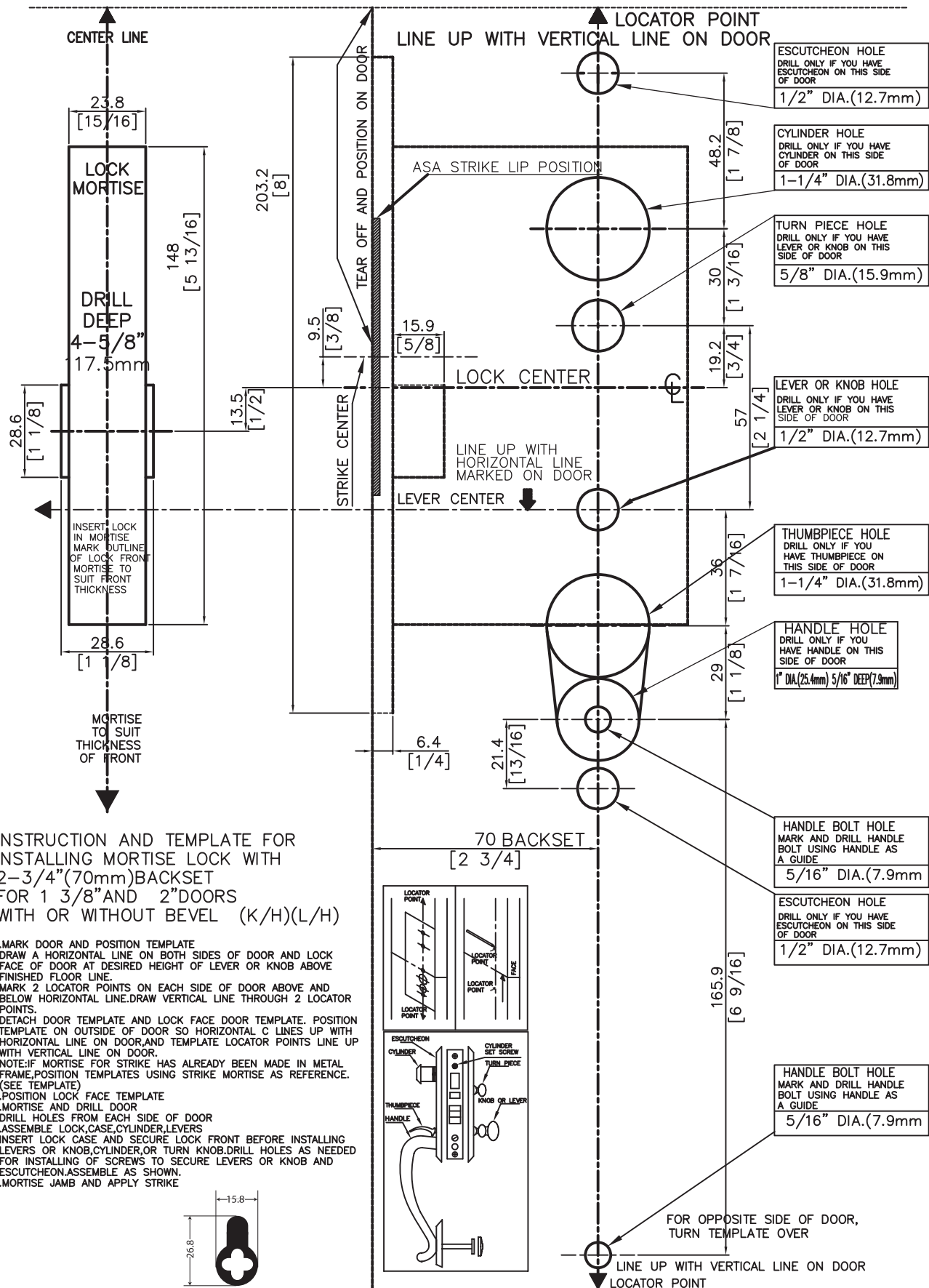

INSTRUCTION AND TEMPLATE FOR
INSTALLING MORTISE LOCK WITH
2-3/4"(70mm)BACKSET
FOR 1 3/8"AND 2"DOORS
WITH OR WITHOUT BEVEL (K/H)(L/H)

1. MARK DOOR AND POSITION TEMPLATE
DRAW A HORIZONTAL LINE ON BOTH SIDES OF DOOR AND LOCK FACE OF DOOR AT DESIRED HEIGHT OF LEVER OR KNOB ABOVE FINISHED FLOOR LINE.
MARK 2 LOCATOR POINTS ON EACH SIDE OF DOOR ABOVE AND BELOW HORIZONTAL LINE. DRAW VERTICAL LINE THROUGH 2 LOCATOR POINTS.
DETACH DOOR TEMPLATE AND LOCK FACE DOOR TEMPLATE. POSITION TEMPLATE ON OUTSIDE OF DOOR SO HORIZONTAL C LINES UP WITH HORIZONTAL LINE ON DOOR, AND TEMPLATE LOCATOR POINTS LINE UP WITH VERTICAL LINE ON DOOR.
NOTE: IF MORTISE FOR STRIKE HAS ALREADY BEEN MADE IN METAL FRAME, POSITION TEMPLATES USING STRIKE MORTISE AS REFERENCE. (SEE TEMPLATE)
2. POSITION LOCK FACE TEMPLATE
3. MORTISE AND DRILL DOOR
DRILL HOLES FROM EACH SIDE OF DOOR
4. ASSEMBLE LOCK, CASE, CYLINDER, LEVERS
INSERT LOCK CASE AND SECURE LOCK FRONT BEFORE INSTALLING LEVERS OR KNOB, CYLINDER, OR TURN KNOB. DRILL HOLES AS NEEDED FOR INSTALLING OF SCREWS TO SECURE LEVERS OR KNOB AND ESCUTCHEON. ASSEMBLE AS SHOWN.
5. MORTISE JAMB AND APPLY STRIKE

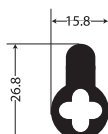

NOTE: STRAIGHT CAM ONLY IS USED FOR HEAVY DUTY MORTISE